



Enclosures & Cabinets for Special Requirements  
comercial@delvalle.es | www.delvallebox.com

# STAINLESS STEEL SOS POST IP66



**10**  
YEARS

STAINLESS  
ANTICORROSIVE  
GUARANTEE

**5**  
YEARS

MECHANICAL PARTS  
GUARANTEE





## WE PUT AT YOUR DISPOSAL

We offer over **45 years** providing solutions to demanding customers who require very specific characteristics and behaviour according to the sector and their needs.

## WHEREVER YOU GO

We are committed to working closely with our customers, providing them with **exceptional service** and offering an advanced and extensive range of products with very competitive prices.

## HIGH STANDARD OF QUALITY AND SERVICES

We only use materials provided by companies who offer the very **highest quality**, suitable and certified products. Our success is due to top quality assurance: ISO 9001, SGS, UL, TÜV, ISO 14000 and Ohsas 18001.

## CUSTOMIZE TOTALLY YOUR ENCLOSURE

Our production systems can give custom-made solutions **on demand**. Every colour from RAL chart is available to be personalized. A variety of protection standards thanks to our own painting facilities.

## CONTACT US

Confidentiality, reliability & quality

www.delvallebox.com  
comercial@delvalle.es  
+34 945 601 381

ALSO ONLINE

### Please contact our technical sales department

A team of professionals with high experience and ability to solve all your queries



# STAINLESS STEEL SOS POST IP66



SOS post 2 modules

CUSTOM  
TO MEASURE



SOS post 3 modules

## The Main Goal of the SOS Post is to Provide a Security Team in an Emergency

The SOS Post consist an emergency station aimed at users and the tunnel's staff, which allows to notify and communicate about any incident happened.

The main goal of the SOS Post is to provide a security team in an emergency, by means of the provision of an emergency telephone and alarm button to allow bidirectional verbal communication between the user and the surveillance staff of the control center. The emergency station should be equipped minimally with an emergency telephone and two fire extinguishers.

➔ [FOR MORE INFORMATION CLICK HERE](#)

## APPLICATIONS

The SOS Post consist an emergency station aimed at users and the tunnel's staff, which allows to notify and communicate about any incident happened.



# STAINLESS STEEL SOS POST IP66

## FEATURES

- The SOS Post is an emergency station which include a minimum security equipment:
  - 1 emergency telephone
  - 2 fire extinguishers
- The SOS Post are installed inside the tunnel, in a specific and safety cells, housed the tunnel's wall. Normally, they are separated every 60 m, in alternative way. Also, they should be located in outsidess areas, close to the accesses.
- The equipment will be powered to the electrical network 230V at 60 Hz, with the corresponding protection equipment. In addition, the cabinet will have an auxiliary power supply.



## TWO MODULES DESIGN

This model consists in an electric cabinet with 2 independent doors.

- 1 SSA cabinet with double BIT closure, designed for the storage of electronic equipment that allows operation of the emergency station. Access to authorized personnel is only allowed (maintenance personnel and montrol menter staff).
- 1 SOS cabinet with double wing close, which allows users to use the security team in an emergency. There is a minimum security equipment. The SOS cabinet has a transparent glass door to permit visibility of the safety equipment.

## OPTIONS

- Manufactured in stainless steel AISI 316L EN 14404.
- Option painted galvanized steel finish in RAL 7035 or another color.
- Possibility of realization of two or three modules.

## NORMATIVE

- Directive 2004/54/EC safety requirements for tunnels in the Trans-European Road
- IEC EN 62208 and EN 60529. IP66 (IP55 double door without mounting, IP66 with central welded bar mounting).
- DIN 40050-9 - IP69K extiend IEC 60529.
- Manufactured following EU low voltage ruling 2014/35/UE.
- Normative IEC 62208 and EN 62262. IK10 resistance.
- Certificate UL Nema 4x, 12, 3r, 1. N° File E342220.

## THREE MODULES DESIGN

This model consists in an electric cabinet with 3 independent doors.

- 1 SSA cabinet with double BIT closure, designed for the storage of electronic equipment that allows operation of the emergency station. Access to authorized personnel is only allowed (maintenance personnel and control center staff). It's a roomy cabinet to storage equipment to guarantee perfect and fast communication with the staff in an emergency.
- 2 independent SOS cabinets, both with a wing lock. The first cabinet allows the service of communication with the personnel of the control center. The second cabinet gives the extinguishing equipment.

# STAINLESS STEEL SOS POST IP66

## PLAN AND REFERENCES TWO MODULES

➔ [CLICK HERE TO DOWNLOAD THE FILES CAD - PLANS - CERTIFICATES](#)



REFERENCES	DIMENSIONS (mm)		
SOS POST 2 MODULES	HIGH - A -	WIDTH - B -	DEPTH - C -
MVAB907537DSOS	900	750	370
Version: Normative UL	Add "UL" to the reference. Ex: "MVAB907537DSOSUL"		
Version: Stainless AISI 316L	Add "S6" to the reference. Ex: "MVAB907537DSOSS6"		
Version: Galvanized	Replace "MVAB" by "MVGB" Ex: "MVGB907537DSOS"		

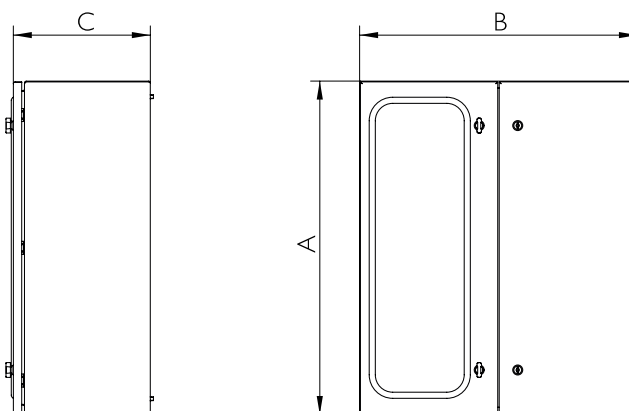

## PLAN AND REFERENCES THREE MODULES

REFERENCES	DIMENSIONS (mm)		
SOS POST 3 MODULES	HIGH - A -	WIDTH - B -	DEPTH - C -
MVAB801537.3PSOS	800	1500	370
MVAB901537.3PSOS	900	1500	370
MVAB101537.3PSOS	1000	1500	370
Version: Normative UL	Add "UL" to the reference. Ex: "MVAB907537DSOSUL"		
Version: Stainless AISI 316L	Add "S6" to the reference. Ex: "MVAB907537DSOSS6"		
Version: Galvanized	Replace "MVAB" by "MVGB" Ex: "MVGB907537DSOS"		

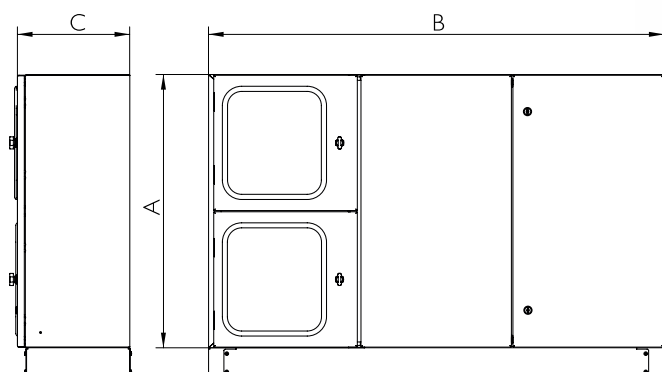

## DELVALLE OFFERS CUSTOMIZED SOLUTIONS

[www.delvallebox.com](http://www.delvallebox.com)

[comercial@delvalle.es](mailto:comercial@delvalle.es)

+34 945 601 381

ALSO ONLINE

→ FOR MORE INFORMATION CLICK HERE

STAINLESS STEEL  
INDUSTRIAL ENCLOSURES



OUTDOOR HEAVY DUTY  
ELECTRICAL ENCLOSURES



OUTDOOR TELECOM 19  
RACKS & CABINETS



GALVANIZED STEEL  
ELECTRICAL ENCLOSURES



HYGIENIC DESIGN ENCLOSURES



ALUMINIUM ELECTRICAL  
ENCLOSURES



## DELVALLE OFFERS CUSTOMIZED SOLUTIONS

[www.delvallebox.com](http://www.delvallebox.com)

[comercial@delvalle.es](mailto:comercial@delvalle.es)

+34 945 601 381

ALSO ONLINE

→ FOR MORE INFORMATION CLICK HERE

### WATERPROOF SHEET STEEL ELECTRICAL ENCLOSURES



### CLIMATE CONTROL COOLING FOR ELECTRICAL ENCLOSURES



### NEMA ELECTRICAL ENCLOSURE TYPE 1-3R-4X-12



### MODULAR DISTRIBUTION ENCLOSURES



### EMC ELECTRICAL ENCLOSURES SOLUTIONS



### CABLE GLANDS & ENTRY SEALS FOR CABINETS





Enclosures & Cabinets for Special Requirements



Paso del Prao, 6. 01320 Oyón (Álava). Spain  
P. +34 945 601 381  
[www.delvallebox.com](http://www.delvallebox.com) - [comercial@delvalle.es](mailto:comercial@delvalle.es)  
**Contact us, we will be available at any time**

