

DEHUMIDIFIER ELECTRICAL ENCLOSURE



GUARANTEE





WE PUT AT YOUR DISPOSAL

We offer over **45 years** providing solutions to demanding customers who require very specific characteristics and behaviour according to the sector and their needs.

WHEREVER YOU GO

We are committed to working closely with our customers, providing them with **exceptional service** and offering an advanced and extensive range of products with very competitive prices.

HIGH STANDARD OF QUALITY AND SERVICES

We only use materials provided by companies who offer the very **highest quality**, suitable and certified products. Our success is due to top quality assurance: ISO 9001, SGS, UL, TÜV, ISO 14000 and Ohsas 18001.

CUSTOMIZE TOTALLY YOUR ENCLOSURE

Our production systems can give custom-made solutions **on demand**. Every colour from RAL chart is available to be personalized. A variety of protection standards thanks to our own painting facilities.



100%
Diseñado y fabricado íntegramente en España
Entirely designed and manufactures in Spain

CONTACT US

Confidentiality, reliability & quality

www.delvallebox.com
comercial@delvalle.es
+34 945 601 381

ALSO ONLINE



Please contact our technical sales department

A team of professionals with high experience and ability to solve all your queries



DEHUMIDIFIER ELECTRICAL ENCLOSURE



Examples

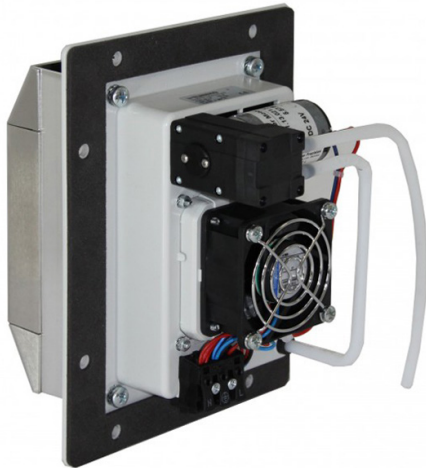

The Solution You Need to Avoid Moisture in your Enclosure

The dehumidifier Delvalle is a special form of switch cabinet cooling technology. There is a fan-free cold plate in the interior of the switch cabinet, on which the air humidity completely condenses. The resulting water droplets run off the plate, are collected in a runnel and drained out of the switch cabinet by a small tube. In order to avoid the formation of ice, the cold plate is equipped with temperature sensor, which keeps the temperature of the cold plate in the ideal range by means of the integrated regulator. Just like our switch cabinet coolers, the switch cabinet dehumidifier is easily installed and is equipped with a temperature protection switch and an alarm relay. The latest generation of our switch cabinet dehumidifier has, in addition to the integrated controller, a connection for a humidistat. With variations of temperature in enclosures it comes to condensation and precipitation of humidity. That causes corrosion, disturbances and breakdown of electrical controls. 3 different versions for various cases of application.

→ [FOR MORE INFORMATION CLICK HERE](#)



DEHUMIDIFIER ELECTRICAL ENCLOSURE

APPLICATIONS

Specially designed for cabinets placed in areas where is necessary to reduce humidity inside the cabinet, PLC'S, external computers, robots, electronic circuits sensitive to humidity excess.





ACCESSORIES

- Hygrostat HYW 90
- Control unit with adjustable times dor dehumidifying and condensate pump
- Mounting bracket for indoor assembly

TECHNICAL FEATURES

ADVANTAGES

- Installation into the side panel or inside the enclosure possible.
- Significant energy saving in comparison to conventional heaters.
- Compact design, low weight.
- Connection by spring-cage terminals.
- Lifetime 100.000 hours at 25°C ambient temperature.
- Alarm switch in case of overheating.
- Equipped with temperature sensor to icing prevent.
- Dirt cannot accumulate inside so the maintenance is zero.
- Respectful with environment.
- Easy installation with screws.
- Tested in extreme weather.

	MVDH0901	MVDH0902	MVDH0903
CONFIGURATION			
CONFIGURATION (*)	Open condensate drip tray	Closed housing, with fan	Closed housing, with fan, with condensate pump
APPLICATIONS	Stationary operation vertical position	Position mobile applications vertical position	Mobile applications variable position or rotation
VOLTAGE	24 V DC		
POWER CONSUMPTION	47 W	50 W	56 W
CONNECTION	Connection cable	Spring-cage terminals	
OPERATING TEMPERATURE	-40°C +60°C		
WEIGHT	1,2 Kg	1,4 Kg	1,6 Kg
DEGREE OF PROTECTION	IP55 outdoor / IP20 indoor	IP55 outdoor / IP20 indoor	IP65 outdoor / IP20 indoor

(*) Hose for condensate drainage belongs to the scope of supply

DEHUMIDIFIER ELECTRICAL ENCLOSURE

NORMS

- IP20 indoor
- IP65 or IP55 outdoor Norm EN 60529.
- Built to CE low voltage.
- Electronic compatibility to EN 300386 and EN 55022.
- Electric safety to EN 60950.



PLANS AND REFERENCES

[CLICK HERE TO DOWNLOAD THE FILES CAD - PLANS - CERTIFICATES](#)

MVDH0901

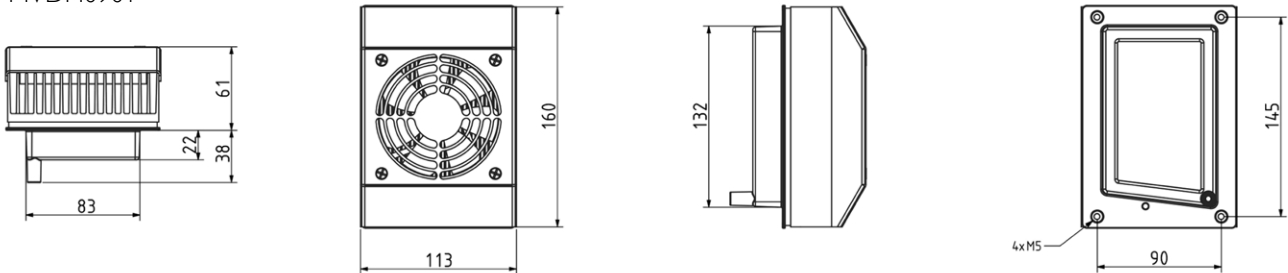

MVDH0902 / MVDH0903

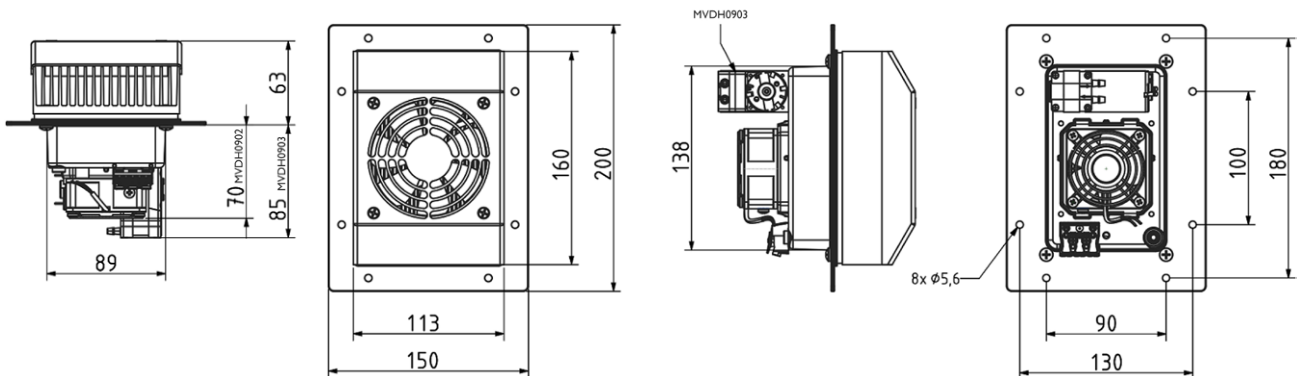

REFERENCES	DESCRIPTION	HIGH	WIDTH	DEEP
MVDH0901	Dehumidifier	160	113	99
MVDH0902	Dehumidifier with fan	160/200	113/150	133
MVDH0903	Dehumidifier with fan and condensate pump	160/200	113/150	148

CUSTOMIZED ENCLOSURE SOLUTIONS DELVALLE

Delvalle has more than 45 years of experience using the latest technology to implement and obtain the most innovative products on offer to all our customers. Delvalle is an ideal partner, combining an advanced and wide range of products at very competitive prices.

The customized manufacture of all electrical enclosures and cabinets Delvallebox is carry out with the most advanced technical methods and with the precision and consciousness of a craftsman. This makes the difference from competitors and is the best way to gain our customers' trust.

In Delvallebox we bear in mind that customers perceive the quality very clearly. In every product (for instance, in the cabinets here presented) safety and useful solutions are what customers value most.



STAINLESS STEEL
INDUSTRIAL ENCLOSURES



OUTDOOR ELECTRICAL
ENCLOSURES



GLOBAL ELECTRICAL
SOLUTIONS FOR URBAN AREAS



GALVANIZED STEEL
ELECTRICAL ENCLOSURES

ATEX INDUSTRIAL ENCLOSURES



SLOPED ROOF
ENCLOSURES - HYGIENIC



INDUSTRIAL ENCLOSURES IP66, IP67, IP68 AND IP69K

Buy direct from manufacturer of custom made IP66, IP67, IP68 and IP69K heavy duty industrial and waterproof electrical enclosures AISI 304L and 316L made by standard IEC 60529. Delvalle has tested all sizes and dimensions of waterproof enclosures according to EN 60529:2018. All weather resistant enclosures are more than simply rainproof, they meet a minimum of Nema 4X and IP66, IP67, IP68 and IP69k requirements to ensure your electronics are protected. From Junction boxes to industrial enclosures, Delvalle weatherproof enclosures offer a wide range of sizes and styles to keep your project waterproof.

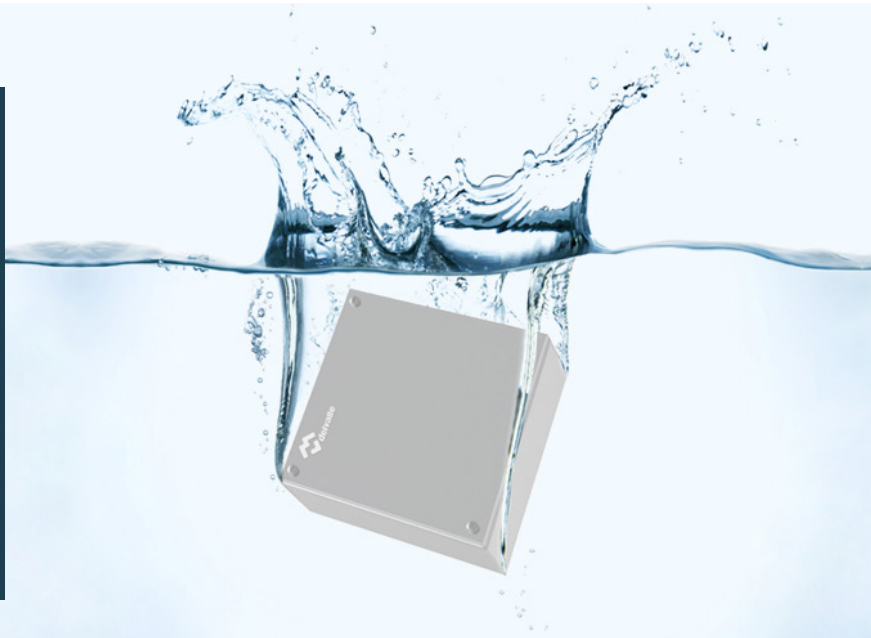

CLIMATE CONTROL COOLING FOR ENCLOSURES



CABLE GLANDS FOR
ELECTRICAL ENCLOSURES





Paso del Prao, 6. 01320 Oyón (Álava). Spain
P. +34 945 601 381
comercial@delvalle.es | www.delvallebox.com
Contact us, we will be available at any time

