

· WE ARE ·
MANUFACTURERS
CERTIFIED



COMPLETE SOLUTIONS

ACCESSORIES

FOR ELECTRICAL ENCLOSURES



ACCESSORIES FOR ELECTRICAL ENCLOSURES

4

CABLE GLANDS AND PLUGS	5	MOUNTING PLATE	13
LIGHTINGS	5	SUPPORT RAILS	13
CUSTOMIZED SURFACE FINISH	6	PLATE SUPPORT	14
TREATMENT COATING "SUNTERM"	6	WATERPROOF SEAL	14
THERMAL INSULATOR TERMOTISA	6	MODULAR CHASSIS	14
TREATMENT ANTI-POSTER	6	PIVOT FRAME	14
SWITCHBOARD GRAFFITI-PROOF PAINT	6	RACK SUPPORT	15
DESIGNS / DOORS	7	WALL MOUNTING BRACKETS	15
CLEAR GLASS DOOR	7	POLE MOUNT	15
PROTECTION FRAME WINDOW	7	TRANSPORTATION ANGLE	16
SET WITH INNER DOOR	7	CABLE TRY	16
DOOR RETAINER	8	CROSS CABLE GUIDE	16
SHOCK ABSORBERS	8	UNION KIT	16
ELECTRONIC OPENING HANDLE	8	REINFORCING FRAME	16
OPEN DOOR SECURITY DEVICE	8	CABLE TRAY	17
STABILIZER REDUCER LUMINOUS FLUX	8	TRAY	17
LOCKS	9	FIXED TRAY	17
SAFETY LOCK	9	COLLAPSIBLE TABLE	18
HANDLES	10	DATA POCKET	18
SECURITY HANDLE	10	ANTI-VANDAL KEYBOARD	18
ROOFS	11	PEDESTAL STANDS	18
SOCKETS	12	EYEBOLT	18
VENTILATION BRACKETS	12	LEVELLING FEETS AND WHEELS	19
ANTI-INSECTS BRACKETS	12	CUT OFF SWITCH	19
SPACING INSULATORS FOR ENCLOSURES	12	BOXES AND STORAGE CABINETS FOR UPS	19
CABLE ENTRY COVER	13	DOOR-LOCKING SYSTEM	19
SLIDING CABLE COVERS	13		



Paso del Prao, 6. 01320 Oyón (Álava), Spain
Phone +34 945 601 381
comercial@delvalle.es | www.delvallebox.com

1.23



WE PUT AT YOUR DISPOSAL

We offer over **50 years** providing solutions to demanding customers who require very specific characteristics and behaviour according to the sector and their needs.

WHEREVER YOU GO

We are committed to working closely with our customers, providing them with **exceptional service** and offering an advanced and extensive range of products with very competitive prices.

HIGH STANDARD OF QUALITY AND SERVICES

We only use materials provided by companies who offer the very **highest quality**, suitable and certified products. Our success is due to top quality assurance: ISO 9001, SGS, UL, TÜV, ISO 14000 and Ohsas 18001.

CUSTOMIZE TOTALLY YOUR ENCLOSURE

Our production systems can give custom-made solutions **on demand**. Every colour from RAL chart is available to be personalized. A variety of protection standards thanks to our own painting facilities.



100%
*Entirely designed
and manufactured
in Europe*

CONTACT US

Confidentiality, reliability & quality

www.delvallebox.com

comercial@delvalle.es

+34 945 601 381

ALSO ONLINE

Please contact our technical sales department

A team of professionals with high experience and ability to solve all your queries



ACCESSORIES FOR ELECTRICAL ENCLOSURES

**We give a Solution
Complete with the Installation
of Components**

Examples



Delvalle accessories are specially designed for use in box and electrical enclosures. We recommend the installation of the components, for a complete solution of the assembly, the closing and the finishes. Discover the most common components that can be added to electrical cabinets: retainers, shock absorbers, canopies, cable glands, ...



[FOR MORE INFORMATION CLICK HERE](#)

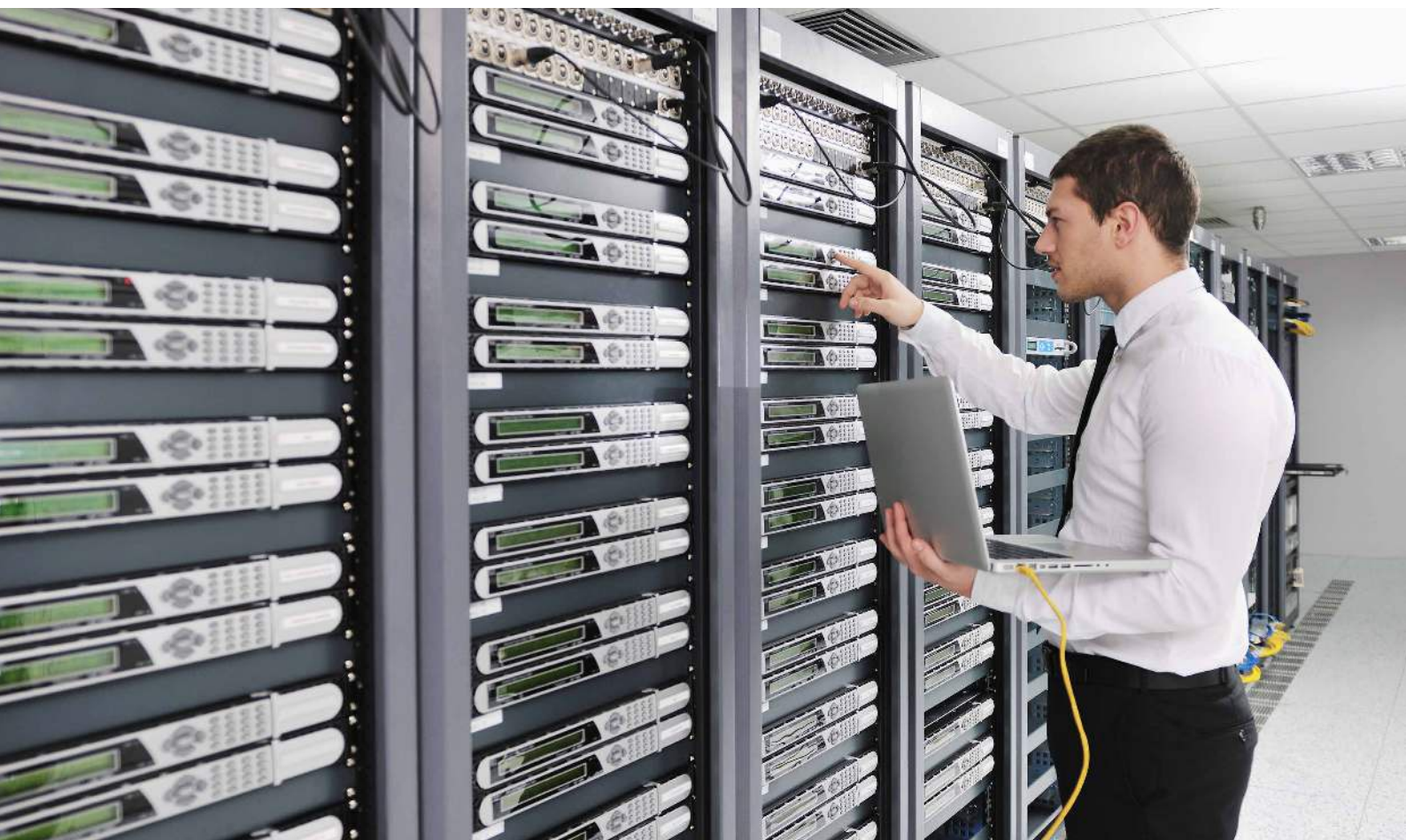

SOLUTIONS ACCESSORIES FOR ELECTRICAL ENCLOSURES

CABLE GLANDS AND PLUGS



The valves are suitable for passing, holding and compressing cables between two compartments, such as junction boxes, cabinets, electrical boxes or devices requiring sealing against dust, dirt or water. Wide variety, and top quality available in stainless steel AISI 303 and 316, brass, nickel fiberglass, polyamide reinforced ATEX (see table below), EMC shielded, with a protection to IP68... All models are certified UL,Ce,TÜV and carry a European manufacturer's warranty. We have a cable gland placement service in our enclosures available.

Additional information available on request.

LIGHTINGS

Delvalle compact luminaires are specially designed for use in electrical cabinets.

We have low consumption luminaires with LED or the fluorescent tube standard.

With screw fixing both on the width side and the narrow side, optionally this fixing can be magnetic by magnet.

They can also have an integrated power socket, which allows you to connect additional electrical devices.

Different models and consumptions depending on the chosen cabinet, with plug, for UL, with motion sensor and different powers, frequency, lumens, etc.

Additional information available on request.

REF: MVSL01 (Luminaire support)

REFERENCE	MODELS	DIMENSIONS	POWER	LM
MVCLGT2312	Fluorescent line light	60x385x35 mm	10 W	-
MVCLGL233	LED Schuko	95x268x43 mm	5 W	380 LM
MVLC2701	Fluorescent Schuko	95x268x43 mm	11 W	900 LM
MVCL6L232	LED lighting multiposition without movement	40x350x30 mm	6W	700 LM
MVCL6L232.S	LED lighting multiposition with movement	40x350x30 mm	6W	700 LM



MVCLGT2312



MVCLGL233



MVLC2701



MVCL6L232



Lighting structure

SOLUTIONS ACCESSORIES FOR ELECTRICAL ENCLOSURES

CUSTOMIZED SURFACE FINISH

The surface finish in epoxy-polyester paint used by Delvalle is long lasting and provides its cabinets with a decorative finish. We offer a wide range of colours based on the RAL system, using RAL 7032 and 7035 as our standard colours. The benefits offered by this finish over other types are: a wide range of textures and colours, resistance to corrosion and a long-lasting surface finish that is less susceptible to chips, marks and scratches. In addition, all of our cabinets have passed the strictest quality controls according to the American UL guidelines, meeting all the necessary low voltage standards and watertightness levels.



TREATMENT COATING “SUNTERM”

SunTerm treatment coating for use in outdoor electrical enclosures, contain a reflective component that deflects the infrared light, and thus the half of the sun's total energy, from any substrate that it coats. As a result, the surface of the substrate, and any interior ambient that it protect, are cooler than a standard coating. As a treatment solution SunTerm also gives you high corrosion resistant for outdoor environments.

REF: MODEL + SUNTERM

THERMAL INSULATION FOR ELECTRICAL PANELS TERMOTISA

Delvalle I+D department has specially designed the insulating TermoTisa X100, in 15mm polyurethane with a coated porous braided polyester support sheet, to be installed on the enclosure walls and so ensure a thermal insulation of 0.0365 W/mk. We also have the insulating TermoTisa X220 is an insulating product resistant to extreme temperatures of 220°C for 1.000 hours, it contains the high quality melamine based foam. The material is resistant to liquids; doesn't peel off, is self extinguishing and insulates the electrical current.



TREATMENT ANTI-POSTER

Outdoor cabinet antiposter, specially designed for public lighting, urban furniture, city hall, shopping centers, buildings ... Its design with rumble strips prevents the sticking of posters. It is also aesthetically more elegant. Available in two materials: aluminium and galvanized steel with epoxy polyester paint.

REF: MODEL + ANTIPOSTER

SWITCHBOARD GRAFFITI-PROOF PAINT

In Delvalle, all cabinets may be supplied with a protective transparent anti-graffiti paint and anti-fingerprint, preventing vandalism if paint is easily removed.

REF: MVV04PIN

SOLUTIONS ACCESSORIES FOR ELECTRICAL ENCLOSURES

DESIGNS / DOORS

The possibility of placing a double door in the cabinet is given to meet the customer's need to improve maneuverability and to be able to keep one part closed while working on the other.
Available in sizes from 800x600.

Consult us for more information.



CLEAR GLASS DOOR

All our cabinets are available with transparent exterior and interior doors for perfect vision of electrical components or indicators that are inside while protecting them from direct contact with liquids. Approved fire resistant polycarbonate manufacture. High impact resistance DIN 52290, BS 6206. Safety glass BS 5544. Fire resistance DIN B1, B2.

REF: Just add to your reference the letter "T".

PROTECTION FRAME WINDOW

Manufactured in stainless steel, it is used to provide maximum viewing capacity of the indication elements and protection of the controls or indicators, and is transparent and resistant to chemicals.

Due to its design it can be directly fitted to the electronic cabinet in any position. It avoids external manipulation and is an economic, easy to fit solution. Made in AISI 304 stainless steel, or as an option in AISI316, with UL certificate and IP66-IP67 watertight integrity.



REFERENCE	DIMENSIONS (mm)				
REFERENCE	HIGH	WIDTH	DEPTH	HIGH FRAME	WIDTH FRAME
MVAH4040	400	400	60	340	340
MVAH4040	400	500	60	340	440
MVAH4060	400	600	60	340	540
MVAH5040	500	400	60	440	340
MVAH5050	500	500	60	440	440
MVAH5060	500	600	60	440	540
MVAH6040	600	400	60	540	340
MVAH6050	600	500	60	540	440
MVAH6060	600	600	60	540	540



SET WITH INNER DOOR

Interior door designed for direct placement in the enclosure. With different designs and finishes as required.

REF: Add to reference letters "TC" (See references in each enclosure)

SOLUTIONS ACCESSORIES FOR ELECTRICAL ENCLOSURES



DOOR RETAINER

Door retainers are used to keep doors open safely. We have two materials: galvanized steel and stainless steel.

REF: MVRT01 (Galvanized)

REF: MVRT01S (Stainless steel)

SHOCK ABSORBERS

To better hold the doors, as well as define their opening angle and prevent closing abruptly. In different sizes depending on the cabinet.

REF: MVAM01 (2 units)



ELECTRONIC OPENING HANDLE

The opening electronic system Delvalle is an economical solution for cabinets up to two doors. The opening is via a PIN code in the embedded numeric keypad that can be programmed freely with up to 5 different codes custom. After initial programming, the user, by entering your access code, you can make an electric opening handle to open the door. The handle with electronic opening Delvalle is applicable in small installations, where it is not necessary to connect different units to each other and where it is necessary to keep access control and prevent opening of the cabinet by unauthorized personnel.

NOTE: 12V electric power supply at least 300 mA.

REF: MVC116 (Electric power supply)

REF: MVMA07 (Electric handle for 1 door)

REF: MVMA08 (Electric handle for 2 doors)

OPEN DOOR SECURITY DEVICE

This device prevents accidents, alerts the operator that the electrical system is functioning properly. Suitable for connection to three-phase or single-phase lines. It is also a phase loss control device and phase sequence: in case of failure, error warning. The device functions can be increased with auxiliary contacts such as the lamp lighting up on opening the door or to control other equipment within the enclosure (air conditioning).

REF: MVLC2602



STABILIZER REDUCER LUMINOUS FLUX

The stabilizer reducer luminous flux Delvalle is ideal for paintings of street lighting as it ensures that the voltage to the lamps is always within the range of $\pm 2\%$ of the nominal value.

SOLUTIONS ACCESSORIES FOR ELECTRICAL ENCLOSURES

LOCKS

Depending on the enclosure and its use, we look for the best lock suited to the customer's needs. Standard enclosures are manufactured with double-bit locks. We provide closures in polyamide, chrome and stainless steel as standard, also zamak and polyamide handles. We have vandal resistant security closures as well as other inserts. We also have antivibration closures, which prevent inadvertent or accidental opening of the doors.

Types of inserts available:

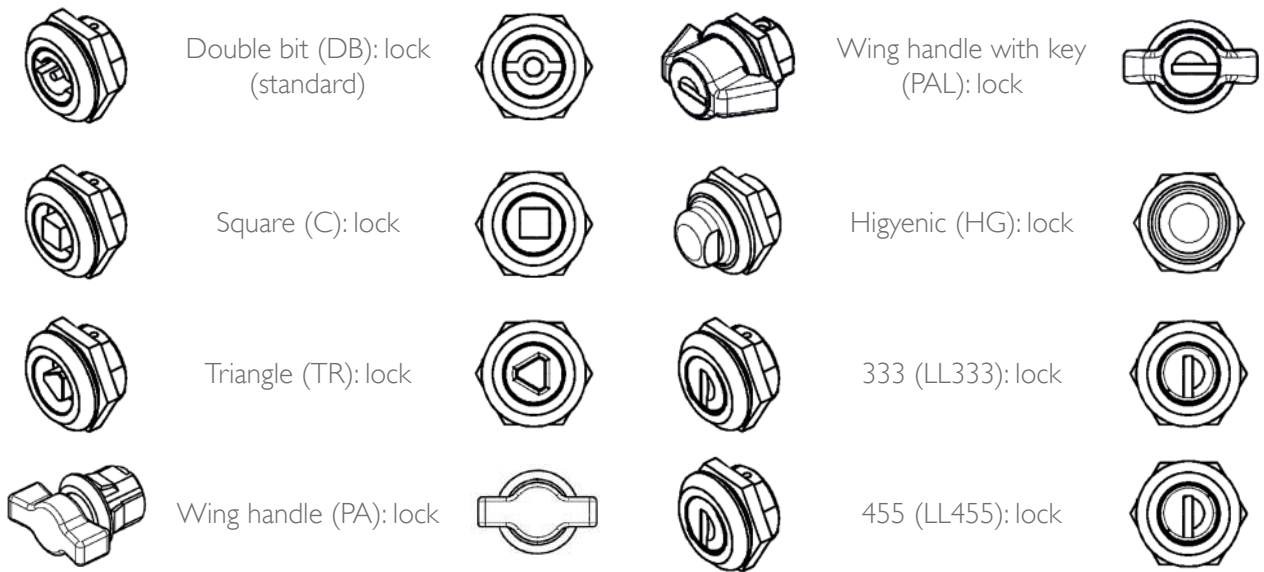

Set the reference with the following parameters. Example: MVCI.01.C (square zamak closure)

1	+	2	+	3	+	4
Type		Material		Closures		Option
MVCI		Zamak: 01 Stainless steel: 02 Polyamide: 03		Double bit: DB Square: C Triangle: TR Wing handle: PA		Anti-vibration: AV
				Wing handle with key: PAL Hygienic: HG 333: LL333 455: LL455		



SAFETY LOCK

Typically used in enclosures with temporary changes of users. You can also use the padlock seal, preventing unauthorized opening the cabinet.

REF: MVCII6

SOLUTIONS ACCESSORIES FOR ELECTRICAL ENCLOSURES

HANDLES

Depending on the cabinet and its subsequent use, we look for the handle that best suits the client's needs; as standard, the cabinets carry the double bit handle, although several types of inserts are available, including those of electric companies.

We have rotating handles in zamak and stainless steel.



Types of handles available:

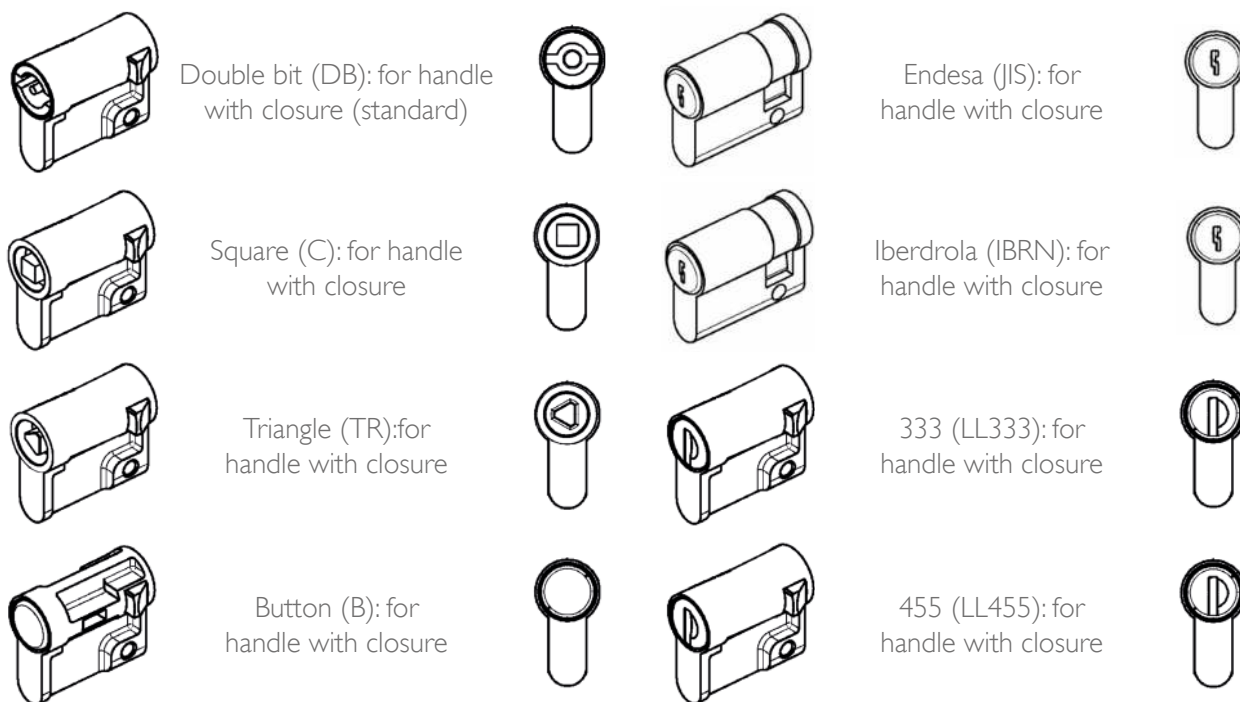

Configure reference with the following parameters. Example: MVMA.01.B (handle button zamak)

1	+	2	+	3
Type		Material		Closure
MVMA		Zamak: 01 Stainless steel: 02		Double bit: DB Square: C Triangle: TR Button: B Endesa: JIS Iberdrola: IBRN 333: LL333 455: LL455



SECURITY HANDLE

Security lock for placement in electrical cabinets. Ideal for placement in urban cupboards, municipalities, outdoor cabinets, etc.. in which it is necessary to protect the enclosures of possible forced openings. They are also used to prevent the opening of these cabinets by unauthorized people. Features: made of Duralumin painted material with high resistance to corrosion and vandalism, a very close joint between the handle and the bezel, prevents insertion of tools for opening, reinforced edge warned against any attempt of breaking hard, 90° turn, sealing against water and dust, IP65 and available in stainless steel material.

REF: MVAMA01 (Aluminium)

REF: MVAMA02 (Stainless steel)

SOLUTIONS ACCESSORIES FOR ELECTRICAL ENCLOSURES

ROOFS

Series A (backward slope). Ideal when we want to keep the front dry water is taken to the rear of the enclosure while preserving the important elements that could be placed in the door.

Series B (forward slope). Done to avoid placing objects on top of the cabinets. The fluids are taken to the front of the enclosure to avoid falling on the back and door.

Series C (double slope). Installation ideal for outdoor use. By design the selfventilation system dissipates heat out effectively without the need to install fans and so achieving significant energy savings.

Series D (back water with front ventilation). It is ideal when we want to preserve the front and its design prevents the placement of objects on the top of the cabinets. The liquids are directed to the back of the cabinet preserving the important elements, with frontal ventilation.

Series E (flat). Its installation is ideal for the exterior. It has extra ventilation, because the dissipation of air to the outside is done on all four sides.

Possibility of ordering self-ventilated roofs.



REFERENCES ROOFS SERIES A - B - C		
REFERENCE	WIDTH	DEPTH
MVTJA3015	300	155
MVTJA3821	380	210
MVTJA4021	400	210
MVTJA5021	500	210
MVTJA6021	600	210
MVTJA6030	600	300
MVTJA8030	800	300
MVTJA1030	1000	300
MVTJA1025	1000	255
MVTJA1225	1200	255
MVTJA1230	1200	300
Version Series B	Change "A" by "B" reference. Ex: "MVTJB3015"	
Version Series C	Change "A" by "C" a la reference. Ex: "MVTJC3015"	

REFERENCES ROOFS SERIES D		
REFERENCE	WIDTH	DEPTH
MVTJD6040	600	400
MVTJD6050	600	500
MVTJD6060	600	600
MVTJD6080	600	800
MVTJD8040	800	400
MVTJD8050	800	500
MVTJD8060	800	600
MVTJD8080	800	800

REFERENCES ROOFS SERIES E		
REFERENCE	WIDTH	DEPTH
MVTJE6080	600	800
MVTJE6060	600	600
MVTJE8080	800	800
MVTJE8060	800	600

SOLUTIONS ACCESSORIES FOR ELECTRICAL ENCLOSURES

SOCKETS

Stainless steel plinthbase 100 and 200 mm high. Allows cabinet to be raised and get extra accommodation for cables increasing the separation between the ground and the door, and easily detachable both front and side.

A) We have closed bottoms to insulate and protect the wiring from moisture.

B) Optionally it can be anchored to the ground so preventing any movement of the cabinet.

We have 2 heights. Set the reference:

1	+	2	+	3
Type		Width		High
MVZA10		2 ^{as} figures		2 ^{as} figures
MVZA20		2 ^{as} figures		2 ^{as} figures

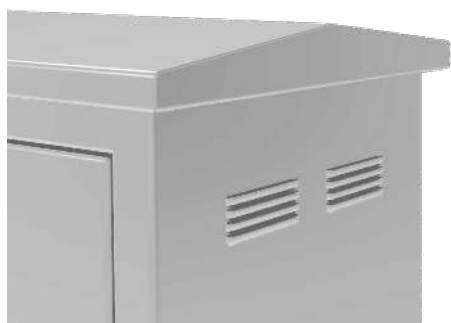

VENTILATION BRACKETS

Placed both in the front enclosure and on the side, allowing a perfect flow of air inside. In combination with a two position fan, one allowing the extraction of air and the other one discharging it into the same on an ongoing basis.

REF: MVV011214

ANTI-INSECTS BRACKETS

We know the problem for the placement of cooling systems posed by the entry of insects inside the cabinet. For this reason Delvalle has designed an anti-insect and easily installed system to answer the problem. In combination with a two position fan, which allows the extraction or air discharge of air on an ongoing basis.

REF: MVVRA



SPACING INSULATORS FOR ENCLOSURES

La solución perfecta para aislar la placa de montaje respecto al armario eléctrico, Adecuados para separar el cuerpo de la placa de montaje en el interior de armarios eléctricos pudiendo trabajar con tensiones de hasta 1200-1500V y pudiendo soportar cortocircuitos.

REF: MVV30308 (30x26 mm)

REF: MVV35320 (35x29 mm)

SOLUTIONS ACCESSORIES FOR ELECTRICAL ENCLOSURES

CABLE ENTRY COVER

Ideal accessory supplement, removable to make holes to suit you comfortably, and fitted so that it is completely integrated into the enclosure.

Depending on the enclosure width one or two covers are used, thanks to the joints included

In two formats:

REF: MVV3512 (354x129 mm)

REF: MVV2590 (250x90 mm)



SLIDING CABLE COVERS

These caps allow cable entry between them. Easily displaced. Contact us for more information.

MOUNTING PLATE

Different plates for different uses:

- Stainless steel: is used to protect and protect electronic components and prevent their manipulation.
- Galvanized: it is the most common. Zinc coated protected against corrosion and easy for making the precut holes.
- Bakelite: used to isolate the different components on the plate.

Enclosures also include perforated plates for quick installation of electrical components. This system saves installation time by more than 270%. They can be mounted both horizontally and vertically. Easy clip-in installation of the elements available in metric M3, M4, M5, M6.

Configure reference (with the product measures):

1	+	2	+	3	+	4
Type		Width		High		Material
MVPM: No perforated MVPP: Perforated		2 ^{as} figures		2 ^{as} figures		I: Stainless steel G: Galvanized B: Bakelite

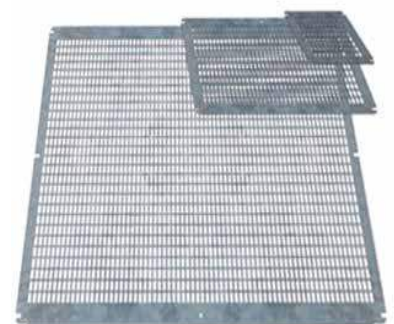

SUPPORT RAILS

Support rails used to incorporate cabinets with scroll ball. So comfort and better access for assembly and use is achieved.

REF: MVCO01

SOLUTIONS ACCESSORIES FOR ELECTRICAL ENCLOSURES

PLATE SUPPORT

The plate support helps in the weight distribution, as well as being a good anchor and can be adjusted to meet needs.
Optional for Titán model.



WATERPROOF SEAL

Injected waterproof seal UL, TÜV, CE certified.
In all electric cabinets a waterproof seal is placed as standard to prevent water and fluid absorption, preventing such entering the enclosure.
Resistant from -40°C to +100°C.

MODULAR CHASSIS

Chassis modular cabinets. Used to divide the front of the cabinets into several sections for quick placement of instrumentation. Using DIN rail, 54mm can be obtained. These chassis can be wired and mounted outside the cabinet for later installation.

They can be placed in any type of wardrobe in our catalog, whether small or large sizes or modular double door.

Chassis design as you need, with no extra cost.

REF: MVV01CH + Width (2^{as} figures) + High (2^{as} figures)



PIVOT FRAME

The ideal solution for the placement of all instrumentation, with easy and comfortable access from the back.

Directly mounted on to the cabinet. With lock or rotating handles as clients need. Adjustable in depth. Reversible opening. Maximum door opening 120°. Various mounting possibilities inside the cabinet.

REF: Add to reference letters "BP"

SOLUTIONS ACCESSORIES FOR ELECTRICAL ENCLOSURES

RACK SUPPORT

Interior solution that provides us with many solutions for the placement of electronic components, computer, network, data, ... This is an internal structure that is placed in the enclosure, either horizontally or vertically, allowing the placement of the required components. Set of 2.

REF: MVV01SOP

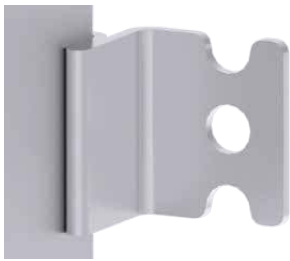

WALL MOUNTING BRACKETS

They are fixed from the outside and can be positioned either vertically or horizontally.

REF: MVSM01 (2 / 4 units)

4 WALL MOUNTING BRACKETS

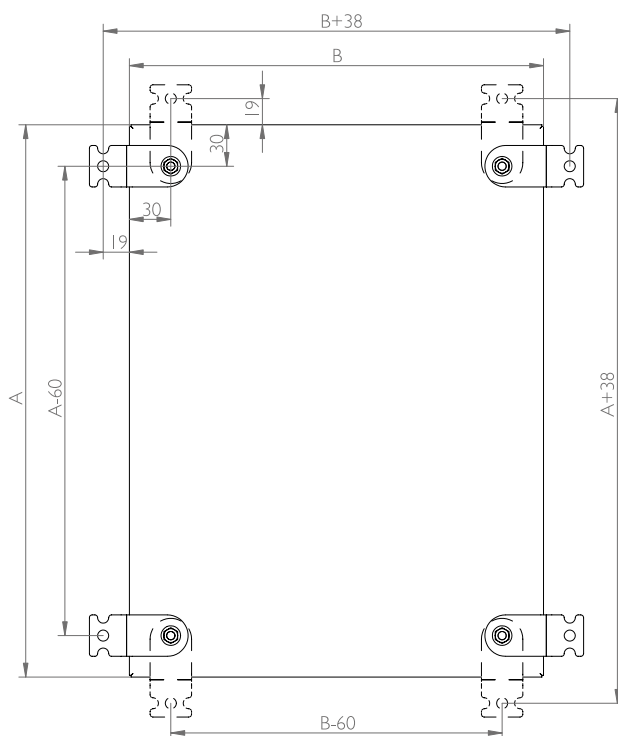

2 WALL MOUNTING BRACKETS

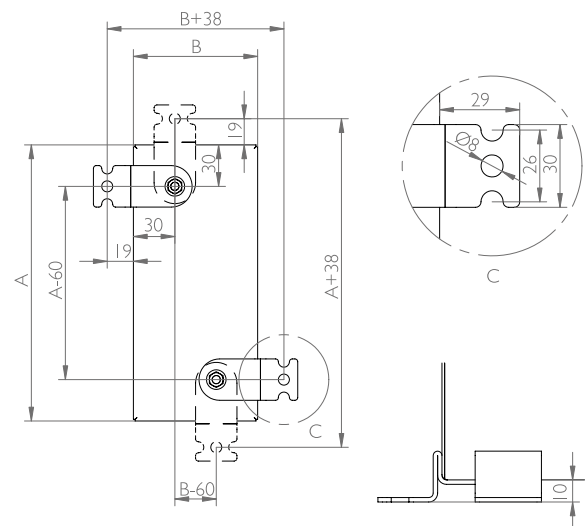

4 WALL MOUNTING BRACKETS			
B	A	<200	=200
<200			
=200			X
>200		X	X

2 WALL MOUNTING BRACKETS			
B	A	<200	=200
<200		X	X
=200		X	X
>200		X	

POLE MOUNT

Sometimes the placement of the cabinet is unusual and we need to adapt it to the environment or certain architectural features. Delvalle, therefore, offers the solution for post mounting, providing a perfect fixing of the enclosure.

REF: MVSM03

SOLUTIONS ACCESSORIES FOR ELECTRICAL ENCLOSURES



TRANSPORTATION ANGLE

The transportation angles add strength in handling loading and unloading of the cabinets. In case of making a large enclosure, or putting a heavy weight inside, Delvalle recommends adding the transportation angle, which adds strength when loading and unloading.

CABLE TRY

Directly fixed to the structure. Galvanized 1.5 mm thick steel. Dimensions: 35mm by 7.5 or 5mm.

REF: MVCDIN01-I



CROSS CABLE GUIDE

With this guide inside the door we get a perfectly ordered wiring. Ideal for the passage of instrumentation in the case of front blanks.

REF: MVTG01

UNION KIT

With this piece we can connect several structures. A seal is also used to reinforce the union as whole, keeping the enclosure completely sealed.

REF: MVPV001919 (Steel)

REF: MVV1842 (Stainless steel)

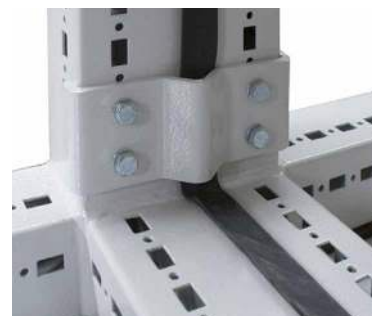

REINFORCING FRAME

Using a reinforced frame in our enclosure gives us more confidence and consistency, especially in the door, but also in the rest of the structure, above all for large enclosures. Suitable for doors from 800 mm.

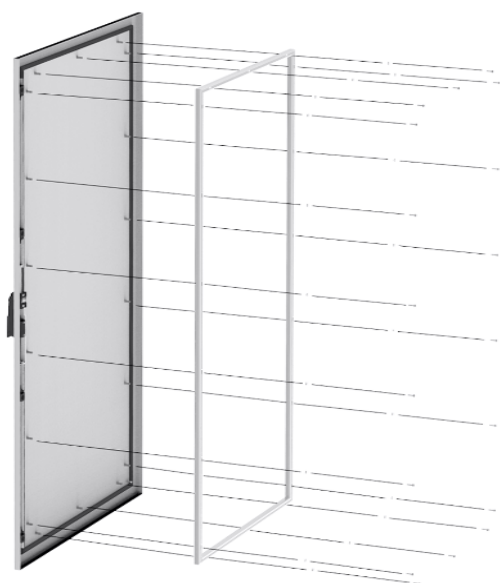
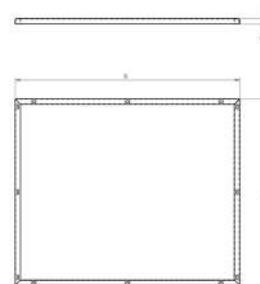

REFERENCES	DIMENSIONS DOOR (mm)			DIMENSIONS FRAME (mm)		
REFERENCES	HIGH	WIDTH	DEPTH	HIGH -A-	WIDTH -B-	DEPTH -C-
MVV03	1000	800	300	900	700	20
MVV03	1200	800	300	1100	700	20
MVV03	1000	1000	300	900	900	20
MVV03	1200	1000	300	1100	900	20
MVV03	1000	1200	300	1100	1100	20
MVV03	1000	1200	300	900	1100	20

SOLUTIONS ACCESSORIES FOR ELECTRICAL ENCLOSURES

CABLE TRAY

Delvalle offers the performance of different widths and lengths of piping and cable trays in stainless steel. Depending on the cable loads to bear, Delvalle offers the performance of different widths and lengths of pipes, cable trays, all in stainless steel. To be designed and manufactured in stainless steel prevents corrosion damage over the years, and getting the highest quality, design and safe installation of wiring inside or outside of the craft. Available in any thickness and any width from 1.2mm to 2mm.



REFERENCES CABLE TRAY				
REFERENCES	A (mm)	B (mm)	LENGTH	SUP. INSIDE
MVBP5060	50	60	2500	27cm ²
MVBP1060	100	60	2500	55cm ²
MVBP1560	150	60	2500	85cm ²
MVBP1590	150	90	2500	129cm ²
MVBP2560	250	60	2500	143cm ²
MVBP2590	250	90	2500	217cm ²
MVBP3560	350	60	2500	201cm ²
MVBP3590	350	90	2500	305cm ²

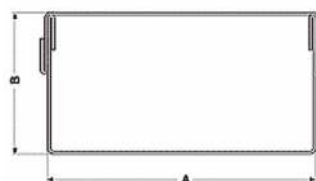

REFERENCES SUPPORT	
REFERENCES	A (mm)
MVBPSP50	50
MVBPSP10	100
MVBPSP15	150
MVBPSP25	250
MVBPSP35	350



TRAY

This solution allows easy removal of any material housed inside the cabinet on the inside trays using the side guides both horizontally and vertically. With different backs and load capacities.

REF: MVV0160EXT

FIXED TRAY

Fixed directly to the cabinet structure, to get separation as well as a shelf for objects. Perforated to improve internal air circulation.

REF: MVV0116050

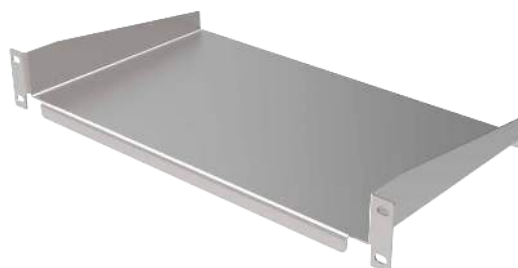

SOLUTIONS ACCESSORIES FOR ELECTRICAL ENCLOSURES



COLLAPSIBLE TABLE

Built in steel or galvanized, with the option of finishing in other colors. Attached directly to the reinforcement of the door frame, adjustable in height in 25mm intervals and so the tray can be placed in 4 different positions.

REF: MVV600600

DATA POCKET

Useful to keep electrical drawings, maintenance records, etc.. Highly resistant made of stainless steel. Fixed with screws or tape.

REF: MVPD503055 (500x300x55 mm)

REF: MVPD302045 (300x200x45 mm)

REF: MVPD191825 (190x180x25 mm)



ANTI-VANDAL KEYBOARD

The anti-vandal PC keyboard is made of stainless steel and meets IP65: shock resistant, rain, water, and / or liquids, in outdoor environments and extreme conditions, compatible with Windows and other systems, ideal for PC Enclosures, Kiosks or information points, high quality key + 1,000,000 clicks.

REF: MVV1292

PEDESTAL STANDS

Steel foot bracket to fix the cabinets to the floor. Allows the cabinet to be placed where protection and distance from the input and output cables in indoor and outdoor facilities is needed. Measures from 500 to 1200 mm in height.

REF: MVAPE01



EYEBOLT

Galvanized in sizes M12 to M20. Set directly onto body of the cabinet, including the possibility of mounting it with the roof already installed.

REF: MVCA01

SOLUTIONS ACCESSORIES FOR ELECTRICAL ENCLOSURES

LEVELLING FEETS AND WHEELS

Levelling feets: height adjustable, anti-slip and vibration. Avoid anchoring cabinets to the floor, gets stably on uneven surfaces and manages to preserve the delicate parts of the cabinets. Wheels: with stainless steel support and nylon wheels.

REF: MVPT01 (Levelling feets)

REF: MVV02RUE (Wheels)

CUT OFF SWITCH

Thanks to the limit switch for electrical enclosures we get a perfect control cabinet lighting and energy savings by preventing any expenses incurred by the forgetting of light off.

REF: MVLC2601



BOXES AND STORAGE CABINETS FOR UPS

Universally accepted optimal solution is to store energy in a storage battery. The optimal solution universally adopted is to store energy in a battery of accumulators. Being able to obtain a continuity of supply of alternating current based on converting the continuous current of said battery into an alternating current of the same characteristics as the commercial network, but without interruptions.

DOOR-LOCKING SYSTEM

A locking system for compact enclosures with several doors. The main door blocks the access to secondary doors.

After the system is unblocked on the main doors, the access to secondary doors is allowed. At the same time, the system prevents the main door from being locked if secondary doors have not been previously locked.



CUSTOMIZED ENCLOSURE SOLUTIONS DELVALLE

Delvalle has more than 50 years of experience using the latest technology to implement and obtain the most innovative products on offer to all our customers. Delvalle is an ideal partner, combining an advanced and wide range of products at very competitive prices.

The customized manufacture of all electrical enclosures and cabinets Delvallebox is carry out with the most advanced technical methods and with the precision and consciousness of a craftsman. This makes the difference from competitors and is the best way to gain our customers' trust.

In Delvallebox we bear in mind that customers perceive the quality very clearly. In every product (for instance, in the cabinets here presented) safety and useful solutions are what customers value most.



STAINLESS STEEL
INDUSTRIAL ENCLOSURES



OUTDOOR ELECTRICAL
ENCLOSURES



GLOBAL ELECTRICAL
SOLUTIONS FOR URBAN AREAS



GALVANIZED STEEL
ELECTRICAL ENCLOSURES

ATEX INDUSTRIAL ENCLOSURES



SLOPED ROOF ENCLOSURES - HYGIENIC



INDUSTRIAL ENCLOSURES IP66, IP67, IP68 AND IP69K

Buy direct from manufacturer of custom made IP66, IP67, IP68 and IP69K heavy duty industrial and waterproof electrical enclosures AISI 304L and 316L made by standard IEC 60529. Delvalle has tested all sizes and dimensions of waterproof enclosures according to EN 60529:2018. All weather resistant enclosures are more than simply rainproof, they meet a minimum of Nema 4X and IP66, IP67, IP68 and IP69k requirements to ensure your electronics are protected. From Junction boxes to industrial enclosures, Delvalle weatherproof enclosures offer a wide range of sizes and styles to keep your project waterproof.



CLIMATE CONTROL COOLING FOR ENCLOSURES



CABLE GLANDS FOR ELECTRICAL ENCLOSURES





INDUSTRIAL ENCLOSURE SOLUTIONS



Paso del Prao, 6. 01320 Oyón (Álava). Spain
Phone +34 945 601 381
comercial@delvalle.es | www.delvallebox.com
Contact us, we will be available at any time